

1 2 3 4 5 6

A B C D E F

A B C D E F

A B C D E F

A B C D E F

1 2 3 4 5 6

A B C D E F

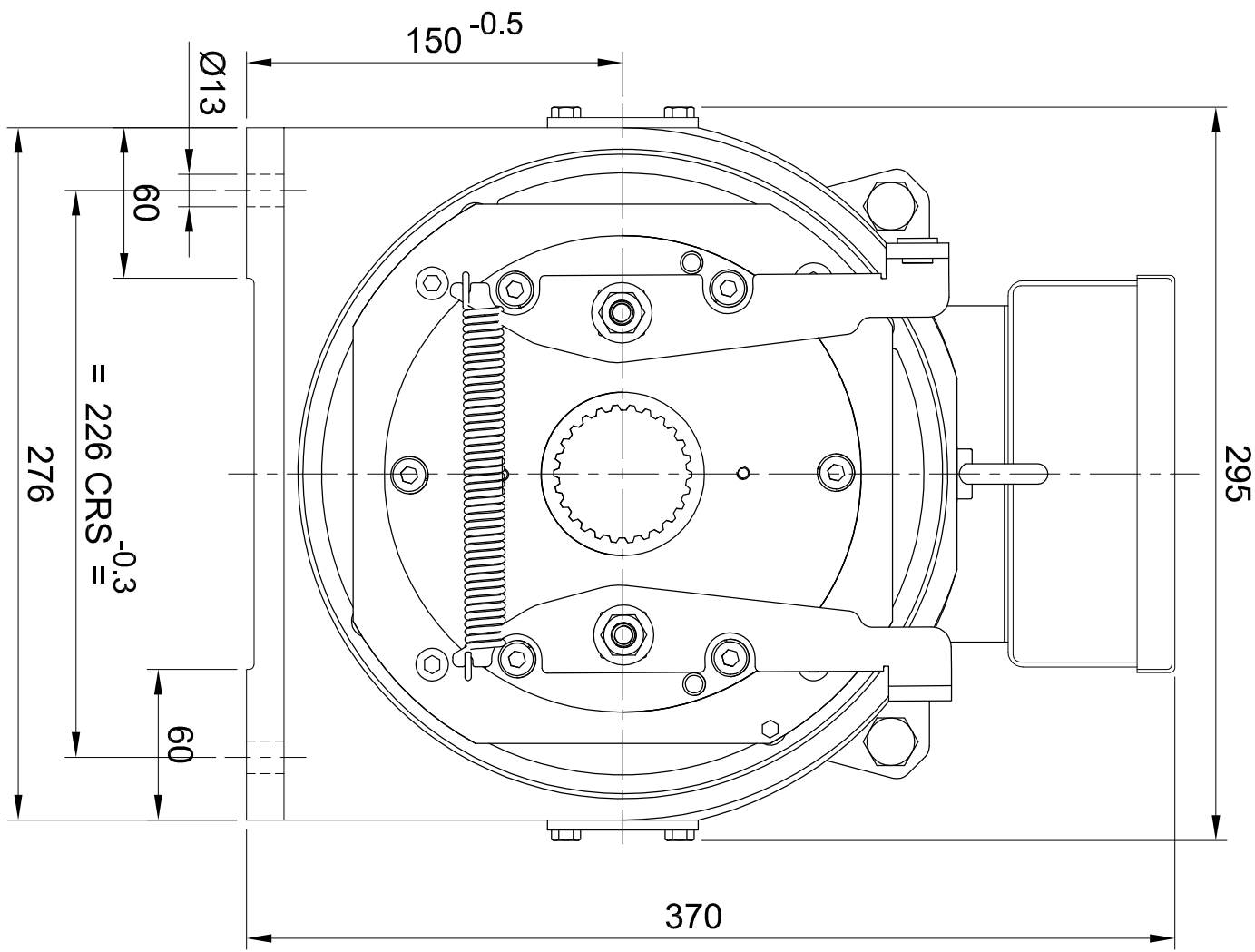
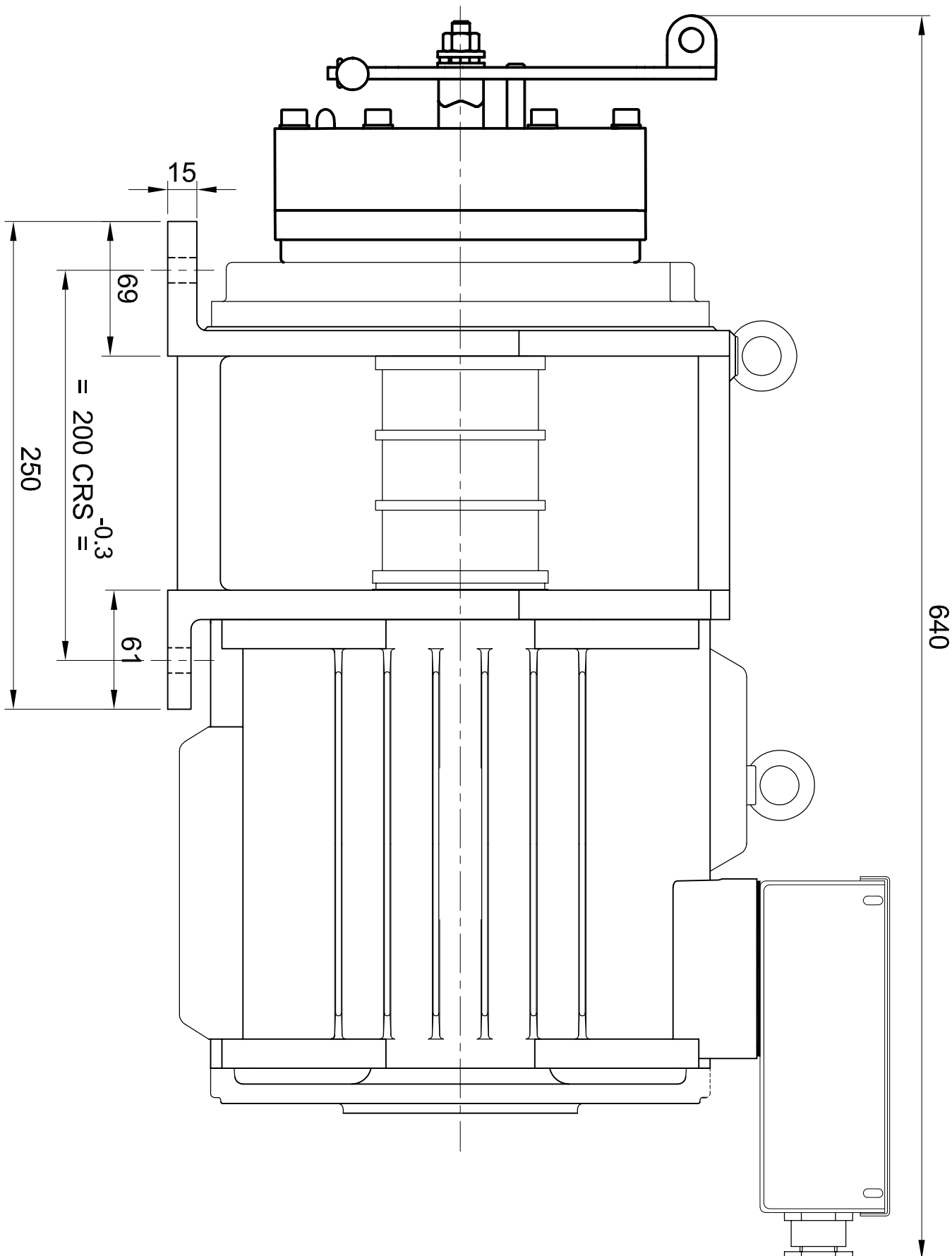

NO. OFF	DESCRIPTION	ITEM NO.	CODE NO.	MATL.	DRG. NO.	PATTERN NO. OR SIZE	WT. kg

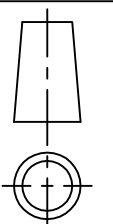

AMENDMENT	DATE	APPD.	TITLE	CODE NO.
D				
C				
B				
A				

NAME	DATE	APPD.	TITLE	CODE NO.
B.D.T.	07.10.16	R.R.	ODD - BELT MACHINE	
V.S.P.	07.10.16			

BHARAT BILEE LTD.

KALWA - THANE

DRG. NO. SES-02-1603

ASSY.DRG.NO.

NO. OF SHEET

ALL DIMENSIONS ARE IN mm. UNLESS OTHERWISE SPECIFIED. TOPFINE FINISH MACHINING (GRINDING) CYMEDIUM FINISH MACHINING THROUGH MACHINING